

KDEPlus

Panel keypad 32x74 for controllers for refrigerated cabinets.



User terminal for full display and programming of controllers for ducted and plug-in refrigerated cabinets. Each power board can be connected to a single KDEPlus keypad and if required to an ECHO module for remote display by means of the connector located on the keypad.

The keypad is not compatible with IWP series instruments.

USER INTERFACE

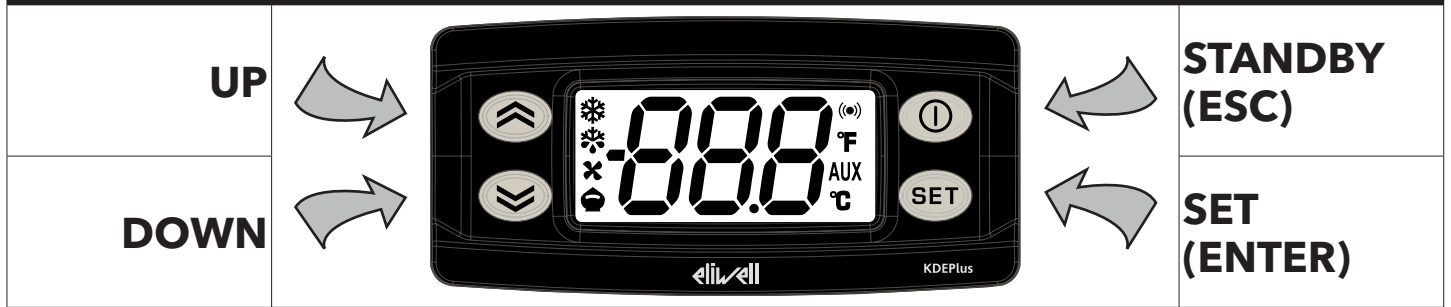

ICONS

	Reduced Set/Economy LED		Alarms LED
	Compressor LED		Defrost LED
	Fans LED	AUX	Aux LED
°C	°C LED	°F	°F LED

MECHANICAL INSTALLATION

The device is designed for panel mounting. Drill a 29x71 mm hole and insert the instrument; secure it with the special brackets provided. Do not install the device in places subject to high humidity and/or dirt; it is intended for use in sites with ordinary or normal levels of pollution.

Keep the area around the instrument cooling slots adequately ventilated.

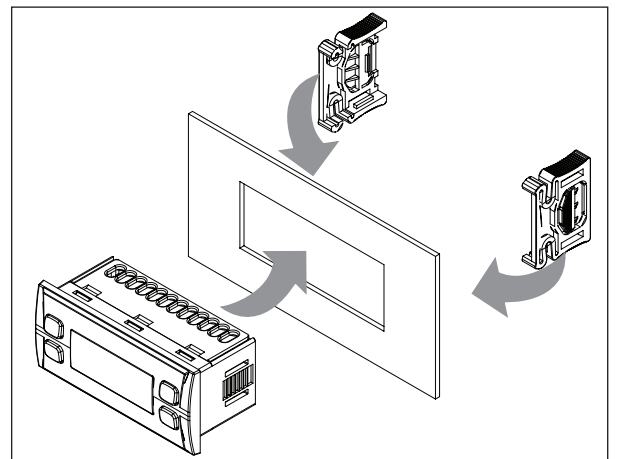
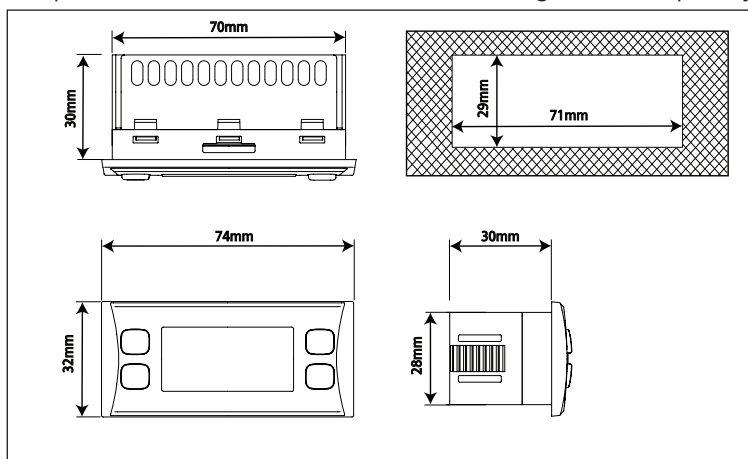

TECHNICAL SPECIFICATIONS

Mounting:	panel mounting with 71x29 mm (+0.2/-0.1 mm) drilling template.
Power supply:	from power board
Casing:	PC+ABS UL94 V-0 resin casing, polycarbonate window, thermoplastic resin keys
Dimensions:	front panel 74x32 mm, depth 30 mm
Terminals:	screw-type for wires with cross-section of 2.5mm ²
Connectors:	JST for connection to ECHO display module
Humidity:	Usage / Storage: 10...90% RH (non-condensing)
Buzzer:	depending on model (to enable it set H29 = 1)

NOTE: For all technical and normative information not indicated in this section, refer to the "Technical Specifications" section of the documents relating to the power board to which the product is connected.

EXAMPLE CONNECTIONS

KDEPlus + RTX-RTN-RTD connection

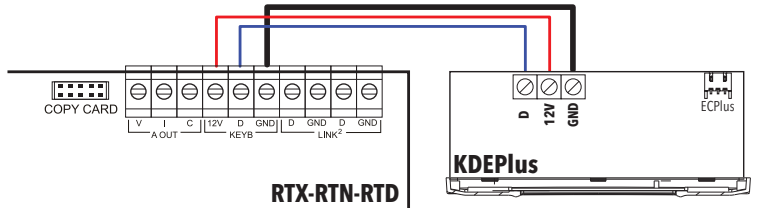
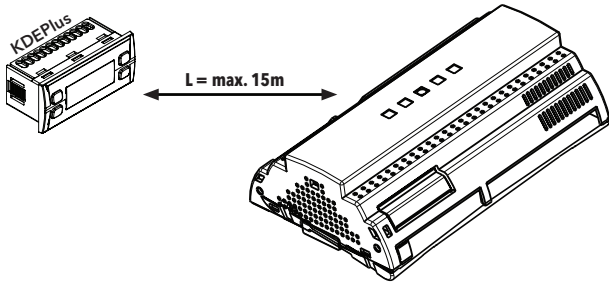

KDEPlus + RTX-RTN-RTD + ECPlus connection

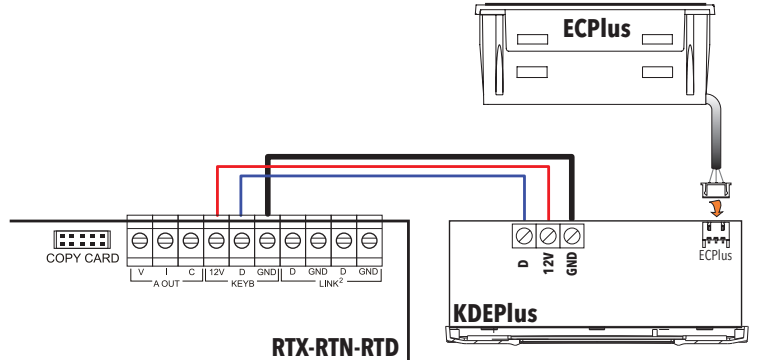
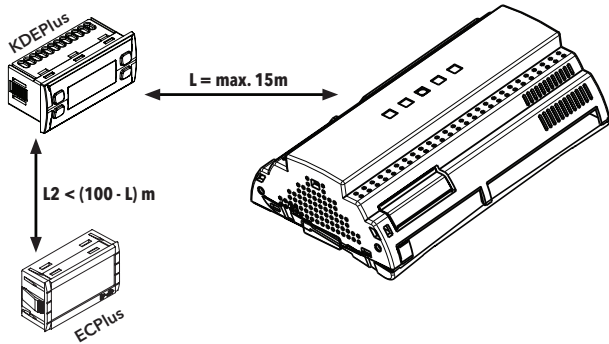

eliwell

Eliwell Controls s.r.l.

Via dell'Industria, 15 • Z.I. Paludi
32010 Pieve d'Alpago (BL) - ITALY
Telephone: +39 0437 986 111
Fax: +39 0437 989 066
www.eliwell.com

Technical Customer Support:

Technical helpline: +39 0437 986 300
E-mail: techsuppeliwell@invensys.com

Sales:

Telephone: +39 0437 986 100 (Italy)
+39 0437 986 200 (other countries)
E-mail: saleseliwell@invensys.com

